

3.1 Operation

This inverter requires two different signals in order for the Inverter to operate correctly. The Inverter requires both an operation setting and a frequency setting.

The following indicates the details of each method of operation and the necessary instructions for operation.

(1) Operation setting and a frequency setting by the terminal control.

This is the method by connecting signals from the outside (the frequency setting, the starting switch etc.) with the control circuit terminals.

The operation is started when the operation setting (FR, RR) is turned ON while the input power is turned ON.

NOTE: The methods of the setting frequency with terminal are the voltage setting and the electric setting.

And they are selective by each system. The control circuit terminal list shows this in detail.

(Necessary things for operation)

[1] The operation setting: switch, relay etc.

[2] The frequency setting: signals from volume or outside (DC0-10V, DC-10-10V, 4-20mA etc.)

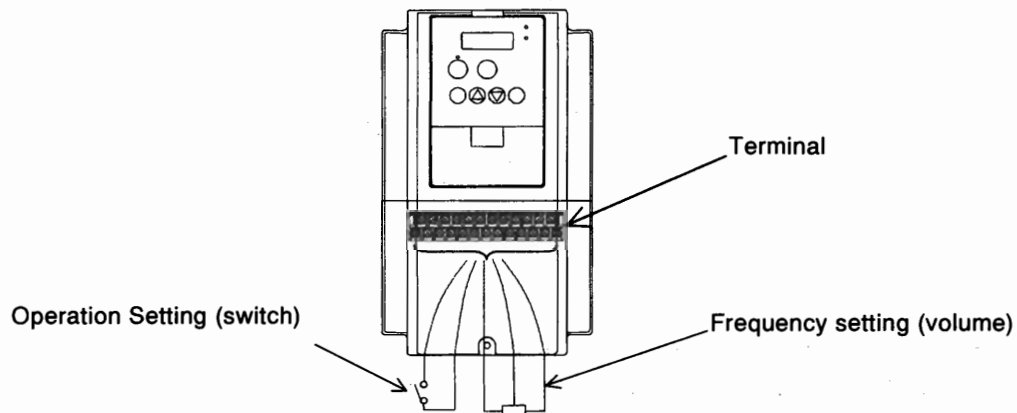

(2) Operation setting and frequency setting with the digital operator.

This is the method for operation from the digital operator, which comes equipped with the inverter as standard, or the remote operator keypad.

When the digital operator sets the operation, the terminals (FR, RR) don't need to be linked.

And it is possible to select frequency from the digital operator as a method of the frequency setting too.

(Necessary things for operation)

[1] Remote Operator (It's unnecessary in case of digital operator operation)

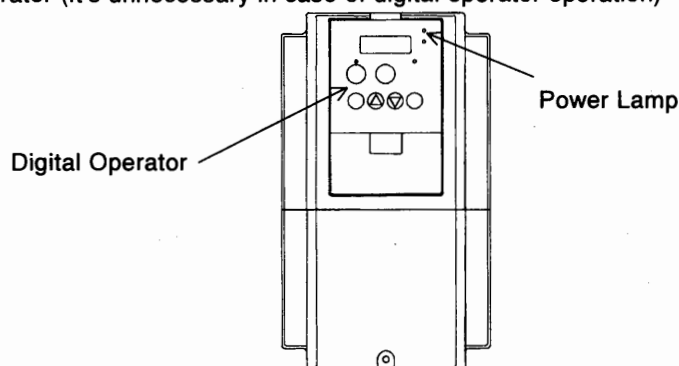

(3) Operation setting and frequency setting from both digital operator and terminal operator

This is the method of inverter operating from both of the above two operating methods

It is possible that the operation setting and the frequency setting can be selected for both the digital operator and the terminal operator each separately.

3.2 Test Run

This is the common connection example. Please refer to 4.1 Digital Operator, for the detailed use of the digital operator.

- (1) To input the operation setting and the frequency setting from terminal control.

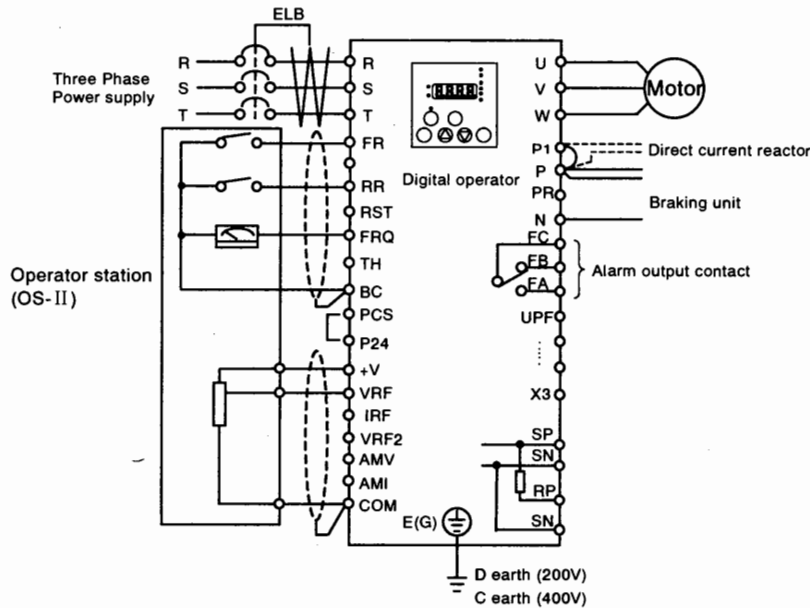

(Arrangements)

- [1] Please make sure that the connections are correctly secure.
- [2] Turn the ELB ON to supply power to the inverter.
(The red LED "POWER" on the digital operator should illuminate.)
- [3] Set terminal with the frequency setting selection.
Set A001 as indication code, press the **(FUNC)** key once. (Two figures are shown.)
Set 01 with the **(1)** key or the **(2)** key, press the **(STR)** key once to set the frequency setting for terminal. (Indication code turns back to A001.)
- [4] Set terminal with the operation setting selection.
Set A002 as indication code, press the **(FUNC)** key once. (Two figures are shown.)
Set 01 with the **(1)** key or the **(2)** key; press the **(STR)** key once to set the operation setting for terminal. (Indication code turns back to A002.)
- [5] Set monitor mode.
When monitoring the output frequency, set indication code to d001, and press the **(FUNC)** key once.
Or when monitoring the operating direction, set indication code to d003, press the **(FUNC)** key once.
- [6] Input starting operation setting.
Turn ON between [FR] and [BC] of terminal.
Impress voltage between [VRF] and [COM] of terminal to start operation.
- [7] Input ending operation setting.
Turn OFF between [FR] and [BC] to stop slowly down.

(2) Operation setting and the frequency setting from the digital operator
 (Copy unit is also same use.)

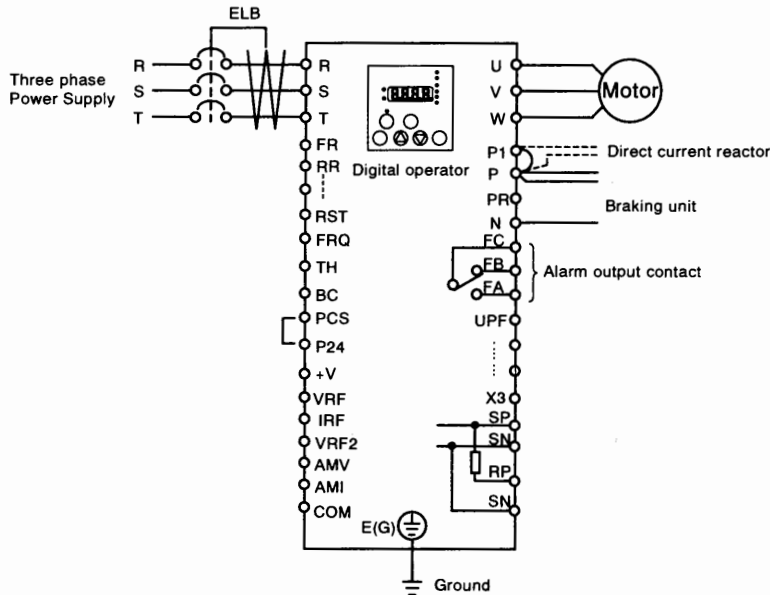

(Arrangements)

[1] Please make sure that there isn't matter about the connection.

[2] Turn the ELB on to supply power to the inverter.

(The red LED "POWER" on the digital operator should illuminate.)

[3] Set operator with the frequency setting selection.

Set A001 as indication code, press the **(FUNC)** key once.

(Two figures are shown.)

Set 02 with the **(1)** key or the **(2)** key, press the **(STR)** key once to set the frequency setting for the operator.

(Indication code turns back to A001.)

[4] Set operator with the operation setting selection.

Set A002 as indication code, press the **(FUNC)** key once.

(Two figures are shown.)

Set 02 with the **(1)** key or the **(2)** key, press the **(STR)** key once to set the operation setting for the operator.

(Indication code turns back to A002.)

[5] Set the output frequency



Set F001 as indication code, as press the  key once.
(Indication code of four figures is shown.)

Set to the desired output frequency with the  key or the  key, press the  key once to store it.



(Indication code turns back to F001.)



[6] Set the operation direction.

Set F004 as indication code, press the  key once.
(00 or 01 is shown.)

Set operation direction to 00 in case of forward, or to 01 in case of reverse with the  key or the  key. Press the  key once to establish it.
(Indication code turns back to F004.)

[7] Set monitor mode.

When monitoring the output frequency, set indication code to d001, and press the  key once.
Or when monitoring the operation direction, set indication code to d003, press the  key once.

(Indication code are  forward,  reverse or  stop.)

[8] Press the  key to start operating.

(The green LED "RUN" turns on a light, and the indication changes in response to the monitor mode set.

[9] Press the  key to decelerate to a stop.

(When the frequency turn back to 0, the green LED "RUN" light will switch off.)

**CAUTION**

Make sure that the direction of the motor is correct. It is in danger of injury or machine damage.
Make sure there is no abnormal noise and vibration. It is in danger of injury or machine damage.

Make sure that there is no tripping during the acceleration and deceleration and check that the revolution per minute and the frequency meter are correct.

When overcurrent tripping or overvoltage tripping occurs during the test run, increase the acceleration time or the deceleration time.